

Technical description

MT23S

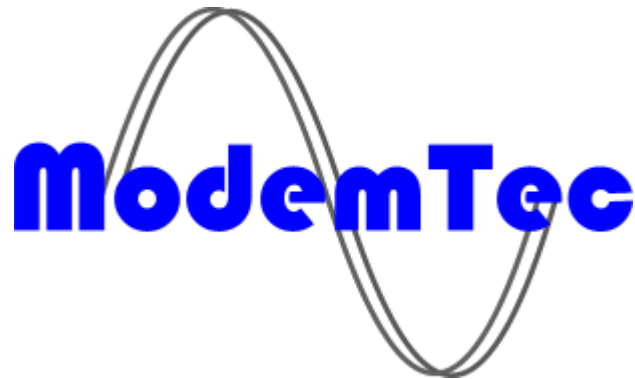

WARNING



The equipment makes a compact setup in a plastic box. Just this setup is safe from point of electrical hazard. Therefore do not use other power supplies or circuits than mentioned in this direction

The equipment is continuously powered from 230V/50Hz network. From this reason any manipulation with the cabinet, leads or parts inside requires extensive care and can be executed just by an authorized person (§6).

The equipment is sufficiently covered just in an IP65 installation box against water and high humidity. (IP65 – dust proof, water jetting resistant).

Do not place the equipment necessarily in close vicinity of heat sources (heat guns, hot air equipment, etc.).



The equipment will work reliably just in an environment given in this service manual. Any arbitrary changes of operation and servicing can cause equipment function deterioration or destruction.

GENERAL INSTRUCTIONS – GENERAL DESCRIPTION

PLC module maintains data transition from PC to other modules (MT22, MT25, MT23R, MT23MB, MT29) and backward.

It is intended for use in 230V 50Hz LV distribution network as a data transmission unit. The module is equipped with an RS232 serial output located on a front equipment panel. It enables portable computer connection and module setup by means of Semod program.

Operation state

It is a basic function of the equipment. In this state it makes a data transition from PC to a distribution network, their reception, saving in memory and backward transition to the PC.

Programming state

It is a state in which equipment parameters are set-up. Parameters are set up from the PC by means of Semod program.

"Beacon" function

The system enables to do an unique and very simple test of communication. A result of this test can be a map of communication over local distribution power network. The map can be used at designing a final version of modules placement and in future to easier system extension or to make failure analysis easier. MT23S module is provided with a „BEACON“function. By a simple insertion of the “Beacon” connector into RS232 communication port the module will be switched over to a state of continual monitoring of the MT22, MT29 or other modules. In such a way a communication test between two points of power network can be done by means of two modules without any preparation and without PC. So the map of communication of a local power node can be obtained and together with customer's requirements an optimal PLC communication can be selected.

PANEL DESCRIPTION AND ITS SIZE

The equipment is embedded inside of Bopla boxes in a table make.

Description of indication lamps and connection points

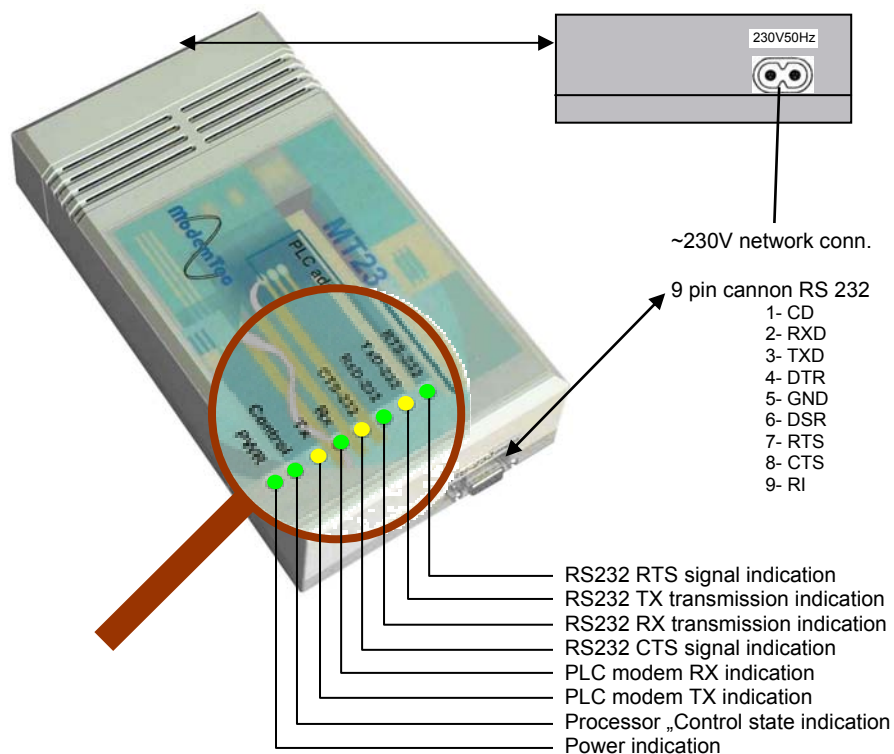

Power indication– indication of MT23 connection to 230V network and 19VDC output voltage presence

Processor “Control” state indication – CPU motherboard state indication, when lit – system is OK

PLC Tx transmission indication– indicates a state of transmission from processor toward power MT23 amplifier– when lit the transmission is active

PLC Rx reception indication – indicates a state of reception toward processor from input MT23 amplifier– when lit the reception is active

RS232 CTS signal indication – indicates a state of MT23R readiness for communication over RS232. LED diode is lit.

RS232 RX reception transition indication– indicates a state of RS232reception input. When the LED diode flashes anyhow or light data reception is active.

RS232 TX transmit transmission indication– indicates an RS232 output. When the LED diode flashes anyhow or light data transmission is active.

RS232 RTS signal indication – indicates a state of equipment connected asking for communication over RS232. LED diode is lit.

MODULE CONNECTION TO A DISTRIBUTION NETWORK

PLC MT23S module installation

TN-C 3 x 400V 50Hz voltage system

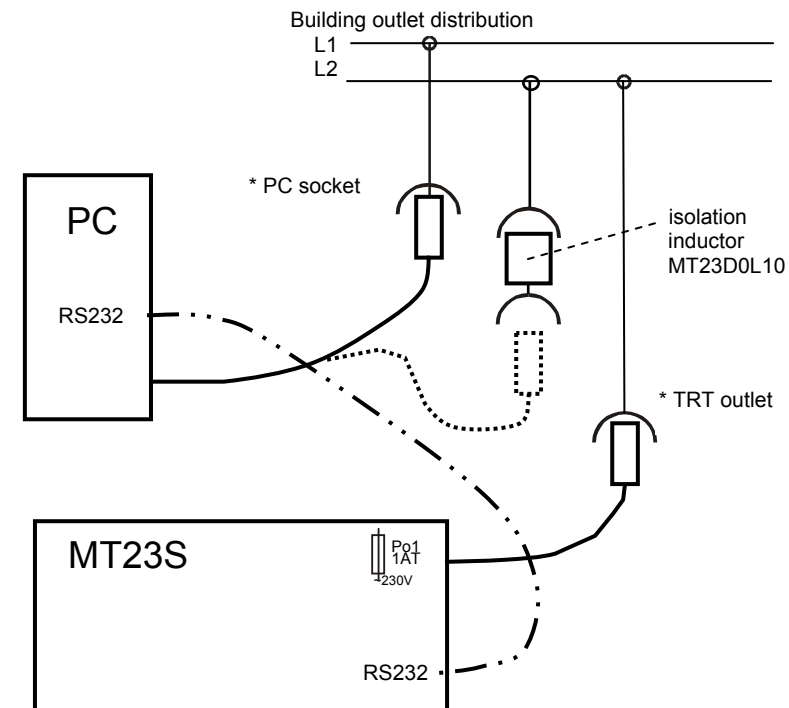

Some PC power supplies and mainly UPS have very low impedance toward communication signals. They act as a short circuit in the range of communication frequencies. The PLC MT23S module is therefore connected to ~230V distribution network so that it is not on the same phase as a close PC. If the configuration cannot be ensured as long as possible connection distance must be chosen or an isolation MT23D0L10 inductor used for PC connection, especially in the case of UPS usage.

GROUP OF MODULES CONNECTION

MT23S modules electrical installation design in vicinity of one power node:

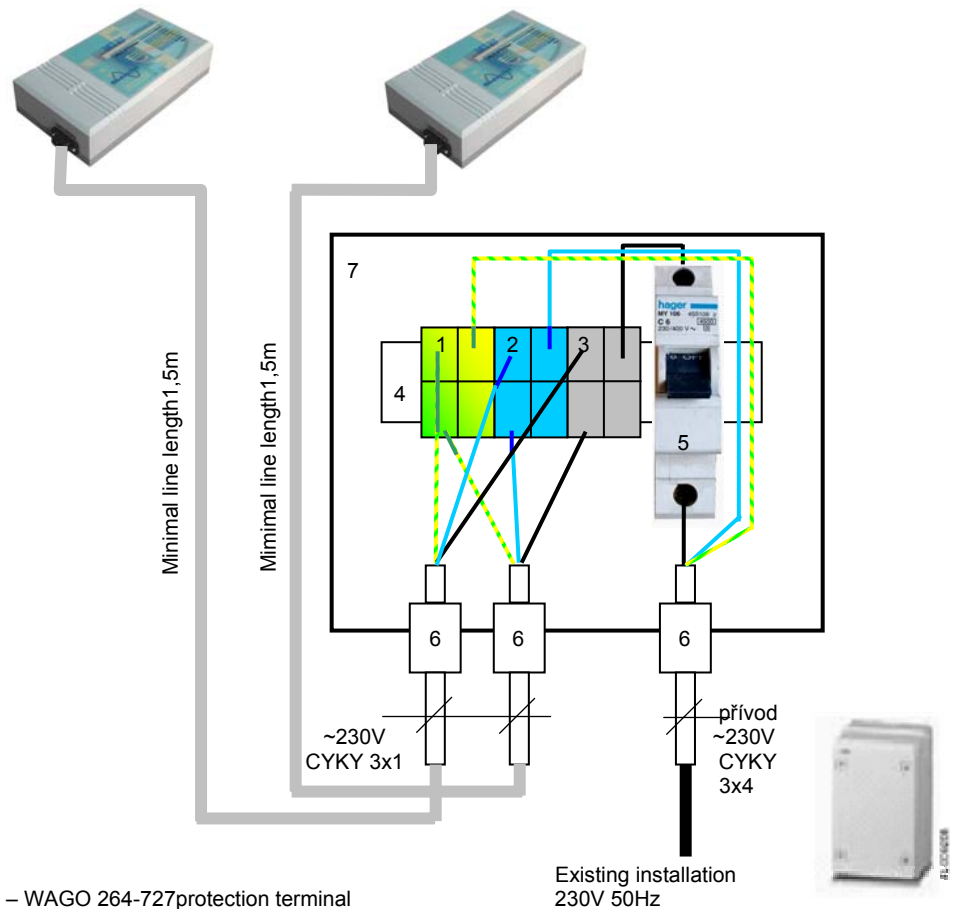

- 1 – WAGO 264-727 protection terminal
- 2 – blue terminal WAGO 264-724
- 3 – gray terminal WAGO 264-721
- 4 – DIN 35 strip
- 5 – 6A breaker (HAGER MY106 C6)
- 6 – cable bushings OBO V-TEC Pg 7, or side box wall tight opening usage
- 7 – ABB 12 804 box, IP65 protection, w x h x d (140 x 220 x 140)

Similar elements of other manufacturers with equivalent parameters can be used. During individual modules connection to the 230V distribution network principles of using wires of certain minimal cross-section must be followed with respect to line breakers used. An impedance loop of breaker reliable cut-off by a short circuit current must not be changed. Otherwise the onwards line must be fused by a new breaker with an appropriate cut-off current (see the picture).

- fuse, breaker 6A –3x1 cable
- fuse, breaker 10A –3x1,5 cable
- fuse, breaker 16A –3x2,5 cable

PROGRAMING STATE

Prior to PLC MT23S module usage its several parameters must be set up. The following parameters can be set up in the PLC MT23S module:
BufRate <1 to 16777215 sec> time between data reading from all modules (max 200) with resolution of 10 time groups and recording the values into a data memory. It means that 10 different „BufRate“ can be set up for 10 observed modules. More about it in Semod program description. > 2sec value is recommended for set up. There is no primary set up.

DLStatusMT23 <1, 0> global permission or prohibition of data reading from observed modules and their data storing in memory. Primary set up is „0“.

DLTimer <1, 65536 sec > the time during which the system enables DLStatus. It changes DLStatus from „0“ to „1“ value. Primary set up is 1000 sec.

Number of repetitions <0, 255 > number of message repetition at unsuccessful communication. This state can come during a strong interference of communication environment when some of messages is so damaged that an addressee is unable to identify it and does not reply a confirmation. Then the MT23S repeats the message, at best, however, in number of repetition set up. The unsuccessful communication is not recorded anywhere. Subsequently the MT23S follows another module. Primary set up is 0.

Modules address <3 byte > module address is divided in two parts. The first part – 1st byte makes a network segment – number of modules group. The other part – 2nd and 3rd byte makes a module direct address.

MT23S address <3 byte > MT23S module address which is authorized to address observed modules. Address is again divided into two parts. The first part -1st byte makes a network segment - number of modules group. The other part -2nd and 3rd byte makes a module direct MT23S module address.

Real time < date and time > it is necessary to set up a real time and date in Semod program by a button. The date and time is transferred to MT23S from PC. MT23S cannot work without this set up. The time is set up primarily. There is a battery backup for real time clock in MT23S module.

A communication with PLC MT23S module is possible via serial interface. User is provided with Semod program which can be installed under MS Windows 98/Me, 2000 and XP operation system. The program provides a tool for set up and operation of individual PLC modules.

OPERATION ERRORS

Various module error conditions can arise during PLC MT23S module operation. Further described are some of basic error conditions with the solution how to get rid of the error.

Nr.	Indication LED status	Malfunction description	Malfunction elimination
1	no LED is lit	No power on module	<ul style="list-style-type: none"> - check the power supply failure - check the power cord - have the module repaired
2	PWR Control is lit	No communication	<ul style="list-style-type: none"> - check for prohibited communication – DLStatus - check RS232 cable between PC and MT23S - check for full MT23S memory and download data into PC - have module repaired
3	PWR, Control is lit, Tx flashes	Module transmits, no reception	<ul style="list-style-type: none"> - possible high interference in network, wait some time - check observed modules switch on state - check communication lines state in network (some communication network parts can be switched off or so) - have module repaired

BASIC PARAMETERS

power	~230V +10% - 15%
frequency	50Hz ± 3Hz
input power	cca 9VA in reception mode cca 20VA in transmit mode
carrier	80kHz ÷ 145kHz
values recording	YES
recording interval	adjustable in range of 1sec to several days
record capacity	cca 6 000 records
protection of recorded data	YES
independent PS	NO
Uart RS232:	
connector	cannon 9 pin
com. rate	19200 Bd
protocol	8,1,N
hardware control	yes RTS/CTS
climate environment	ordinary
modem working temp.	-20 °C až +50 °C
limit temp.	-30 °C až +60 °C
storing temp.	-40 °C až +60 °C
safety class	II
equipment complies with norms:	ČSN EN 12380, ČSN EN 61010-1, ČSN EN 60529, ČSN EN 61000-6-2, ČSN EN 61000-6-3