

Technical description

MT25-Y

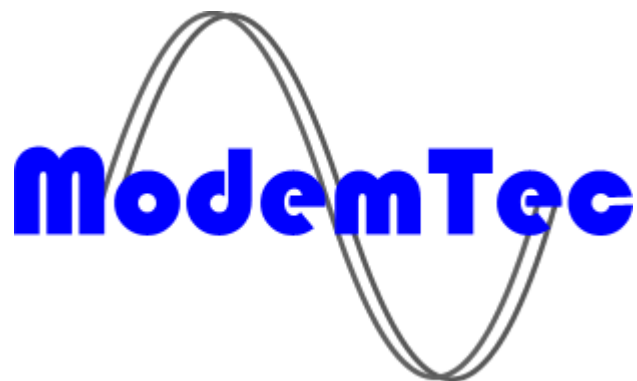

WARNING



The equipment makes a set of two basic modules –MT21PS power supply and link module and MT25-Y status module. Just this setup is safe from point of electrical hazard. Therefore do not use other power supplies or circuits than mentioned in this direction.

The equipment is continuously powered from 230V/50Hz network. From this reason any manipulation with the cabinet, leads or parts inside requires extensive care and can be executed just by an authorized person (§6).

The equipment is sufficiently covered just in an IP65 installation box against water and high humidity. (IP65 – dust proof, jetting water resistant).

Do not place the equipment necessarily in close vicinity of heat sources (heat guns, hot air equipment, etc.).



The equipment will work reliably just in an environment given in this service manual. Any unruly changes of operation and servicing can cause equipment function deterioration or destruction.

GENERAL INSTRUCTIONS – GENERAL DESCRIPTION

It is intended for logic states transition in a pair mode with MT25 -X over LV 230V 50Hz power network. The MT25-Y module has 4 logic relay outputs. They are switching contacts without internal voltage potential.

Operation state

It is a basic equipment function. The MT25Y constantly receives messages from an opposite MT25-X module which sends change messages on logic level of any input over ~230V distribution network.

Programming state

It is a state in which equipment parameters are set-up by means of computer connection to a converter module via serial port and its direct programming.

PANEL DESCRIPTION AND ITS SIZE

The equipment is embedded inside of Bopla CN 55 AK boxes enabling attachment on DIN35 stripe,

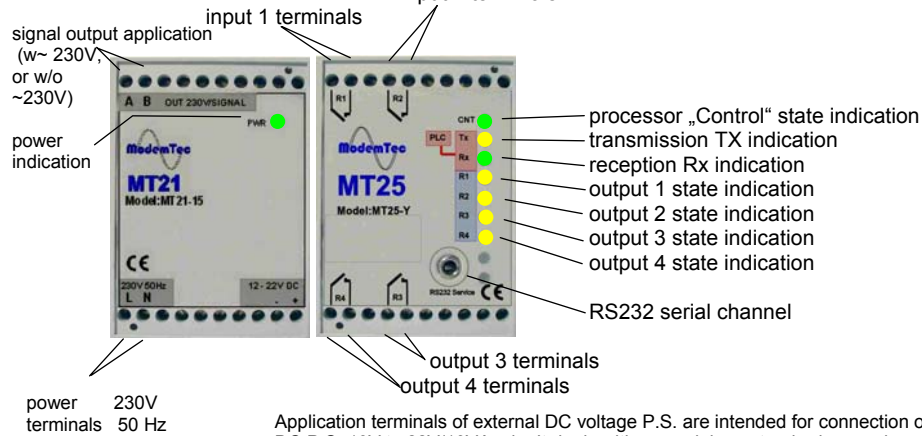

Application terminals of external DC voltage P.S. are intended for connection of external DC P.S. 19V to 22V/10VA min. It deals with a special nonstandard usage in areas without 230V network voltage.

Bopla CN 55 AK:
mat.: ABS

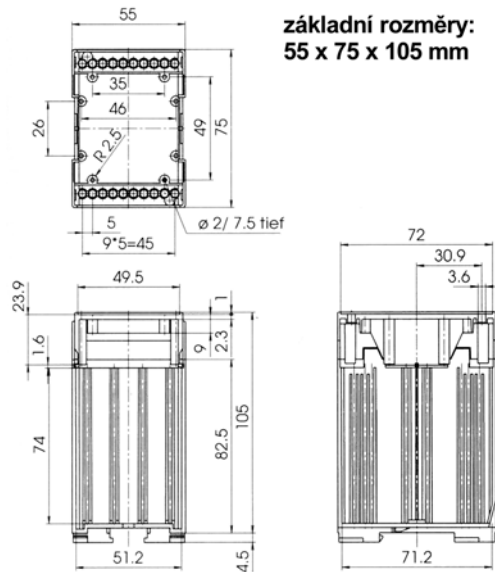

**základní rozměry:
55 x 75 x 105 mm**

Description of indication elements:

Power indication – indication of MT21-1x connection to 230V network and 19VDC output voltage presence

Processor "Control" state indication – CPU motherboard state indication, when lit – system is OK

Tx transmission indication – indicates a state of transmission from processor toward MT21-1x source unit power amplifier – when lit the transmission is active

Rx reception indication – indicates a state of reception toward processor from MT21-1x PS front-end amplifier – when lit the reception is active

Output 1 states indication – indication of logic state relay output 1, when the output is switched-on (log.1) LED is lit

Output 2 states indication – indication of logic state relay output 2, when the output is switched-on (log.1) LED is lit.

Output 3 states indication – indication of logic state relay output 3, when the output is switched-on (log.1) LED is lit.

Output 4 states indication – indication of logic state relay output 4, when the output is switched-on (log.1) LED is lit.

POWER CONNECTION

Electrical installation design:

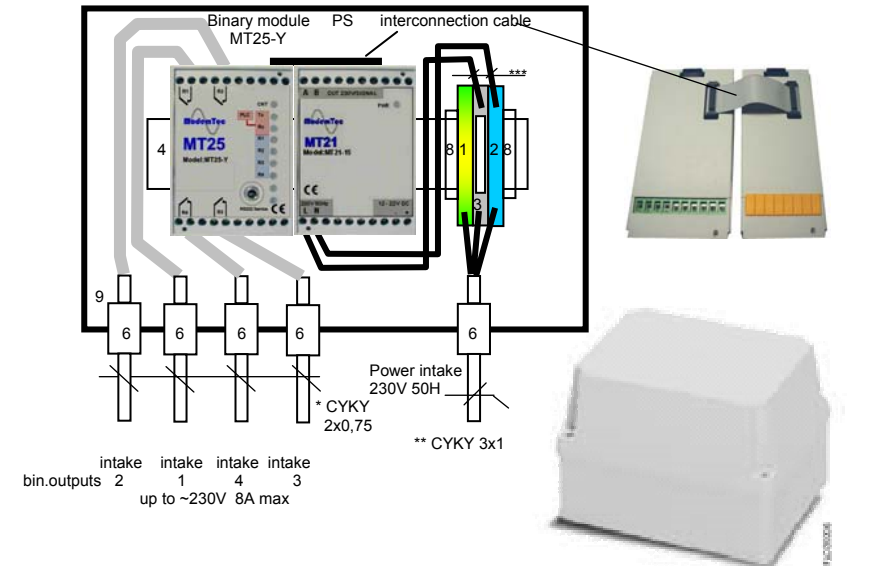

- 1 – WAGO 280-607 protection terminal + 280-331 terminal
- 2 – blue terminal WAGO 280-602
- 3 – gray terminal WAGO 280-612 with a disconnecter or eventually 281-511 fuse holder
- 4 – DIN 35 stripe (as per the box length)
- 6 – OBO V-TEC Pg 7 cable bushings or side box wall tight opening usage
- 8 – WAGO 246-116 DIN 35 stripe end shoe
- 9 – ABB 00 860 box with a high cover, IP55 protection or ABB 12 808 with IP65 protection
 - * - power lead CYKY 2 x 0,75 or bigger cross-section as per current switched
 - ** - power lead as per which breaker is used for intake
 - fuse, breaker 6A – cable 3x1
 - fuse, breaker 10A – cable 3x1,5
 - fuse, breaker 16A – cable 3x2,5
 - *** - use one of power cable wires

Similar elements of other manufacturers with equivalent parameters can be used.

MT21-1x power supply location in respect of MT25-Y module is optional from the point of interaction. Interconnection between MT25-Y module and MT21-1x power supply is realized by means of a flat cable.

| Obj. číslo | Vnitřní rozměry (mm) | Srouby | Balící jednotka/ balení ks |
|------------|----------------------|---------|----------------------------|
| 00 860 | 160x135x150 | ocelové | 1/16 |

Design of MT25-Y modules group electrical installation in vicinity of one power node:

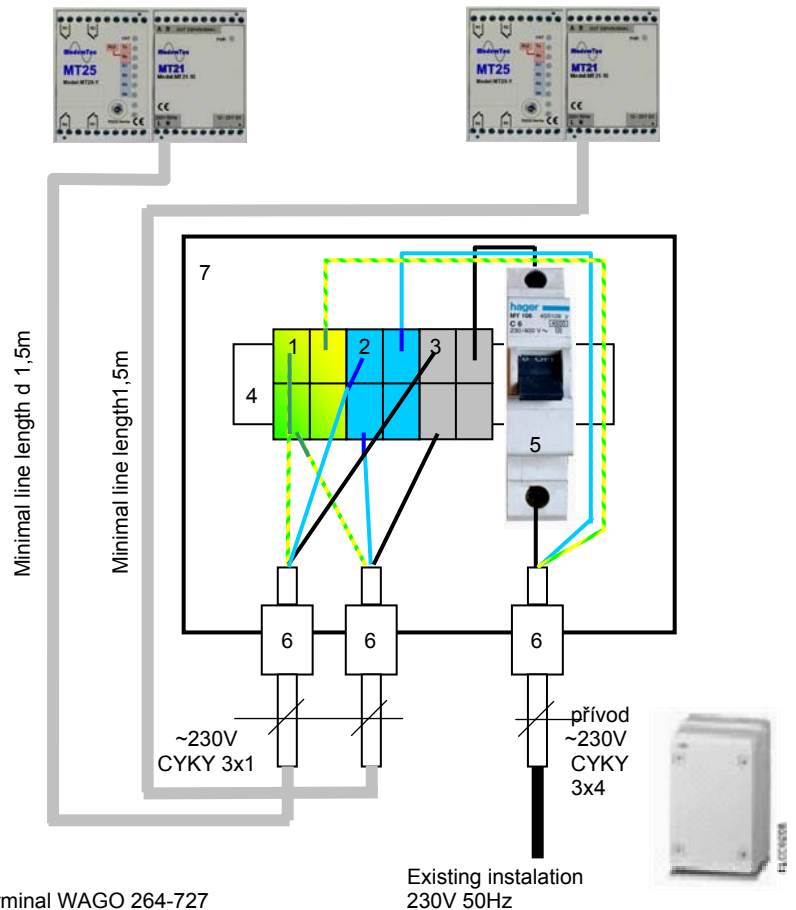

- 1 – protection terminal WAGO 264-727
- 2 – blue terminal WAGO 264-724
- 3 – gray terminal WAGO 264-721
- 4 – DIN 35 stripe
- 5 – 6A (HAGER MY106 C6) breaker
- 6 - OBO V-TEC Pg 7 cable bushings or side box wall tight opening usage
- 7 – ABB 12 804 box, IP65 protection, w x h x d (140 x 220 x 140)

Similar elements of other manufacturers with equivalent parameters can be used.

During individual modules connection to the 230V distribution network principles of using wires of certain minimal cross-section with regard to used line wires must be followed. An impedance loop of breaker reliable cut-off by a short circuit current must not be changed. Otherwise the onwards line must be fused by a new breaker with an appropriate cut-off current (see the picture).

- 6A fuse, breaker – cable 3x1
- 10A fuse, breaker– cable 3x1,5
- 16A fuse, breaker– cable 3x2,5

| Obj. číslo | Rozměry (mm) SxVxH |
|------------|-----------------------|
| 12 804 | 140x220x140 |

BINARY OUTPUTS CONNECTION

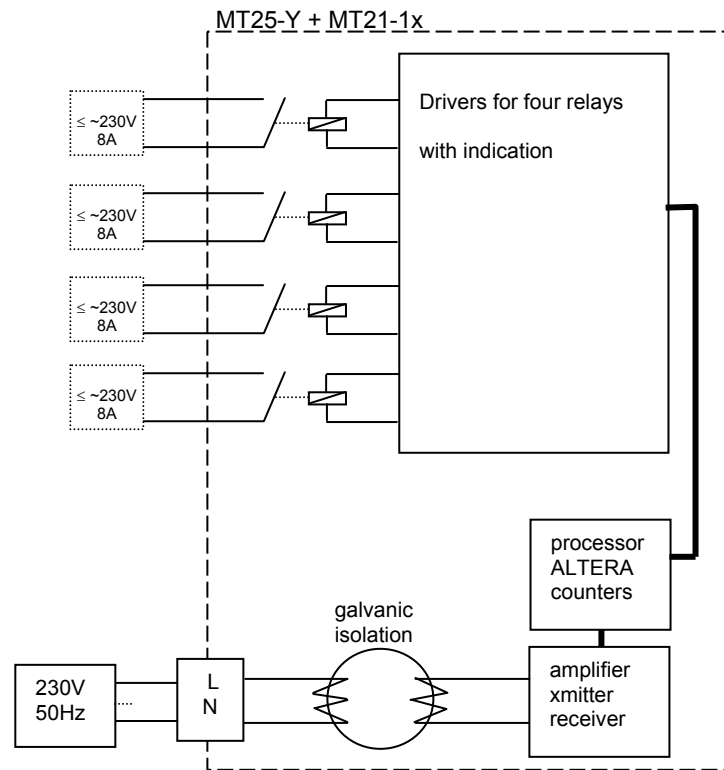

Fujitsu Takamisawa JS-12-K type is used as a switching relay.
Specification:

| Item | | JS ()J-K | JS ()JE-K | JS ()JM-K | JS ()JME-K |
|------------|-----------------------------|-----------------------------------------------------|--------------------|------------|-------------|
| Contact | Arrangement | 1 Form C (SPDT) | 1 Form A (SPST-NO) | | |
| | Material | Au+AgCdO | AgCdO | Au+AgCdO | AgCdO |
| | Resistance (initial) | 30m Ohms (Au 3µm), 100m Ohms (Au 0.3µm) 1A 6 VDC | | | |
| | Rating | 8A 250 VAC / 24 VDC | | | |
| | Max. carrying current | 10A | | | |
| | Max. switching power | 2,000VA/192W | | | |
| | Max. switching voltage | 150VDC/400VAC | | | |
| Time value | Operate | Max. 10ms (at nominal voltage, without bounce) | | | |
| | Release (without diode) | Max. 5ms (at nominal voltage, without bounce) | | | |
| Insulation | Resistance (at 500VDC) | Min. 1,000 Mohms | | | |
| | Dielectric Strength | B/T contacts | 1,000VAC, 1 minute | | |
| | | B/T coil and contacts | 4,000VAC, 1 minute | | |
| | Surge strength | 10,000V (at 1.2x50 µsec.) | | | |
| Life | Mechanical | 20x10 ⁶ operations minimum | | | |
| | Electrical (resistive load) | 100x10 ³ operations min. | | | |

OPERATION ERRORS

Proper PLC MT25-Y module setup must be done before its use. This is done by means of „SEMOD“ program which is not a part of supply. Detailed information can be found in SEMOD instruction manual.

After successful parameters setup according to preceding article the MT25-Y module can come over to regular operation. MT25-Y PLC module supports 1 operation mode:

Pair mode:

In this mode MT25-Y receives logic input state of MT25-X pair module at real time and sets up and accordingly sets up relay outputs. So just these modules communicate together.

During the operation a situation can occur that the connection with the MT25-X module has been broken. In this situation outputs are setup after a critical time expiration according to setup parameters

PAIR MODE PRINCIPLE

In this mode just two modules can communicate together, the best connected to the same phase. At connection on different phases the communication cannot run safely enough, not at all in the worst case.

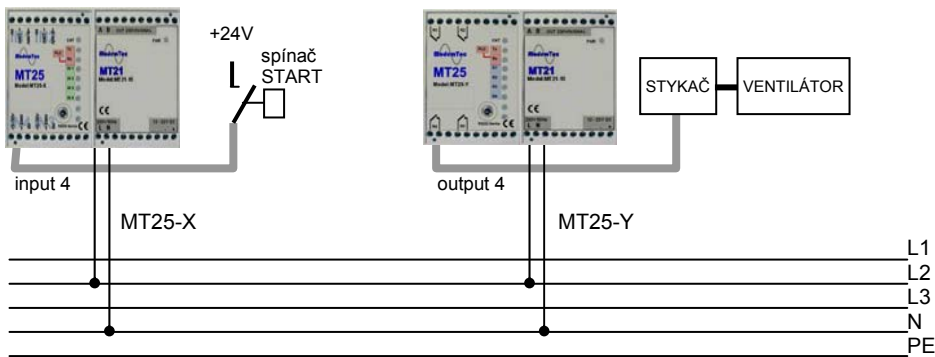

System is used for information transition from MT25-X input side toward MT25-Y output side while the input relay logic can be stopped when needed. At the communication break-up during a time longer than so called refresh time the relay will switch-on (off) according to a set-up parameter (emergency conditions). Input level must be static, it means this level is transferred toward input side during each change. In this example a permanent START switch switch-on will actuate a fan. Its switch-off will stop the fan. A thermometer with hysteresis can be connected instead of the switch that can actuate the fan at set-up temperature overshoot.

Warning:

Just one pair on a set up transmission frequency can be operated within a circuit of one distribution transformer in this mode. When several pairs should be operated (maximum 3 pairs) then each pair must use different transmission frequency. Frequencies in the range of 95kHz to 145kHz can be used. Manufacturer sets the frequency up according to customer requirement.

OPERATION ERRORS

Various module error conditions can arise during operation. Further described are some of basic error conditions with the solution how to get rid of the error.

| No. | Indication LED status | Malfunction description | Malfunction elimination |
|-----|----------------------------------------------------------------------------------------------------|---------------------------------------|----------------------------------------------------------------------------------------------------------------------------------------------------------------------------------------------------------------------------------------------------------------------------|
| 1 | no LED is lit | No power on module | <ul style="list-style-type: none"> - check the power supply – whether green LED lights - check the interconnection flat cable between module and power supply - have the module repaired |
| 2 | CNT is lit other LEDs do not light at all | module does not transmit | <ul style="list-style-type: none"> - check whether input levels of individual inputs change in the range of distinguishing extents, time period of level, see basic parameters - check module parameters setup - have the module repaired |
| 3 | CNT is lit input LEDs light according to input states TX and RX LEDs do not blink | module does not transmit | <ul style="list-style-type: none"> - check module parameters setup - have the module repaired |
| 4 | RX LED does not blink CNT is lit input LEDs light according to input states TX LED blinks | module transmits but does not receive | <ul style="list-style-type: none"> - check module parameters setup – mainly address - modules are connected to different phases, different transformation stations – no connection - have the module repaired |

BASIC PARAMETERS

| | |
|-------------------------------------|------------------------------------------------------------------------|
| usage | state replicator |
| number of points controlled | 4 |
| output levels | |
| relay | 1 switching contact |
| voltage | do ~230V |
| I | 8 A max at real load $\cos\varphi = 1$ |
| current load | 2 A max at $\cos\varphi = 0$ |
| climate environment | normal |
| working temperature | -20 °C to +60 °C |
| limit temperature | -30 °C to +70 °C |
| storage temperature | -40 °C to +80 °C |
| external power supply voltage U_n | + 15V to+19V |
| current consumption from PS | cca 0,13 A |
| Safety class | II |
| equipment complies with norms: | ČSN EN 61010-1, ČSN EN 60525, ČSN EN 61000-6-2, ČSN EN 61000-6-3 |